

Model LD — 11.2 K-factor Large Drop Upright Sprinklers, Standard Response Specific Application Control Mode

General Description

The 11.2 K-factor, Model LD Upright Large Drop Sprinklers are glass bulb type automatic sprinklers. They are a type of specific application control mode sprinkler intended for use with National Fire Protection Association "large drop sprinkler" installation criteria for the protection of high piled storage. The LD Sprinklers can provide a higher level of protection than standard spray sprinklers and, in some cases, they can provide an economic advantage by eliminating in-rack sprinklers.

WARNING

The 11.2 K-factor, Model LD Large Drop Upright Sprinklers described herein must be installed and maintained in compliance with this document, as well as with the applicable standards of the National Fire Protection Association, in addition to the standards of any other authorities having jurisdiction. Failure to do so may impair the performance of these devices.

The owner is responsible for maintaining their fire protection system and devices in proper operating condition. The installing contractor or manufacturer should be contacted with any questions.

IMPORTANT

Always refer to Technical Data Sheet TFP700 for the "INSTALLER WARNING" that provides cautions with respect to handling and installation of sprinkler systems and components. Improper handling and installation can permanently damage a sprinkler system or its components and cause the sprinkler to fail to operate in a fire situation or cause it to operate prematurely.

Sprinkler Identification Number

TY5153 - Upright, 11.2 K

TY5153 is a redesignation for C5153.

Technical Data

Approvals

UL and C-UL Listed. NYC Approved under MEA 289-04-E.

Maximum Working Pressure

175 psi (12,1 bar)

Pipe Thread Connection

3/4 inch NPT or ISO 7-R3/4

Discharge Coefficients

K = 11.2 GPM/psi^{1/2}
(161,3 LPM/bar^{1/2})

Temperature Ratings

155°F/68°C, 200°F/93°C, and
286°F/141°C

Finish

Natural Brass

Physical Characteristics

Frame	Bronze
Button	Bronze
Sealing Assembly	
.	Beryllium Nickel w/Teflon †
Bulb	Glass (5 mm dia.)
Compression Screw	Brass
Deflector	Bronze

† DuPont registered trademark.

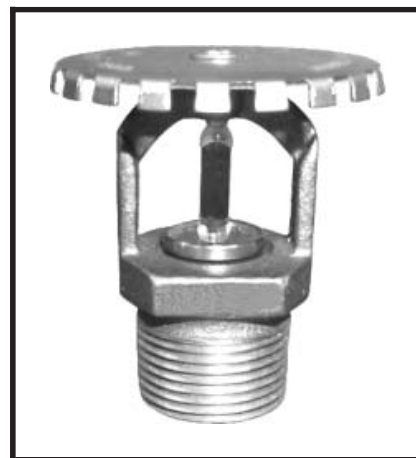

Design Criteria

The 11.2 K-Factor, Model LD (TY5153) Upright Large Drop Sprinklers are only for use with National Fire Protection Association "large drop sprinkler" installation criteria.

Operation

The glass bulb contains a fluid that expands when exposed to heat. When the rated temperature is reached, the fluid expands sufficiently to shatter the glass bulb allowing the sprinkler to activate and flow water.

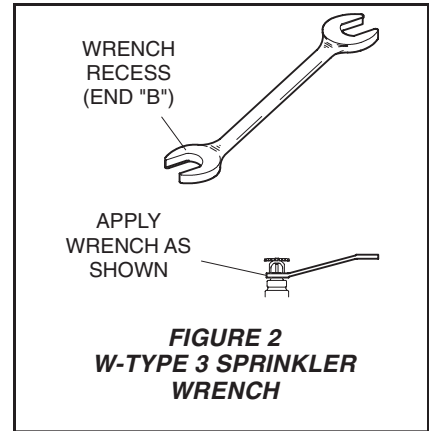
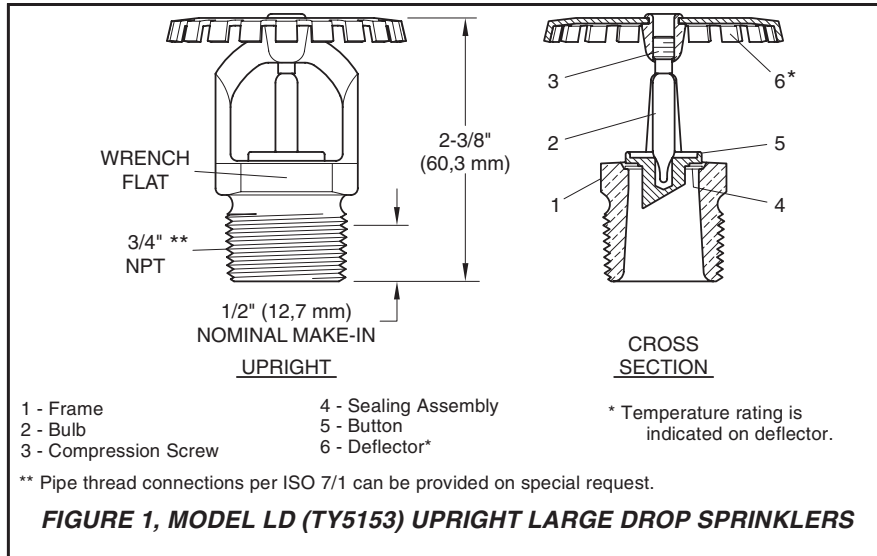

Installation

NOTE

Do not install any bulb type sprinkler if the bulb is cracked or there is a loss of liquid from the bulb. With the sprinkler held horizontal, a small air bubble should be present. The diameter of the air bubble is approximately 1/16 inch (1,6 mm) for the 155°F/68°C to 3/32 inch (2,4 mm) for the 286°F/141°C rating.

The Model LD Sprinklers must be installed in accordance with the following instructions:

Step 1. With pipe thread sealant applied to the pipe threads, hand tighten the Model LD Sprinkler into the sprinkler fitting.

Step 2. Using the W-Type 3 (End B) Sprinkler Wrench (Ref. Fig. 2) applied to the sprinkler Wrench Flats (Ref. Fig. 1), tighten the Model LD Sprinkler into the sprinkler fitting.

NOTE

A leak tight 3/4 inch NPT sprinkler joint should be obtained with a torque of 10 to 20 ft.lbs. (13,4 to 26,8 Nm). Higher levels of torque may distort the sprinkler inlet with consequent leakage or impairment of the sprinkler.

Care and Maintenance

The Model LD Sprinklers must be maintained and serviced in accordance with the following instructions:

NOTE

Before closing a fire protection system main control valve for maintenance work on the fire protection system that it controls, permission to shut down the affected fire protection systems must be obtained from the proper authorities and all personnel who may be affected by this action must be notified.

Sprinklers that are found to be leaking or exhibiting visible signs of corrosion must be replaced.

Automatic sprinklers must never be painted, plated, coated, or otherwise altered after leaving the factory. Modified sprinklers must be replaced. Sprinklers that have been exposed to corrosive products of combustion, but have not operated, should be replaced if they cannot be completely cleaned by wiping the sprinkler with a cloth or by brushing it with a soft bristle brush.

Care must be exercised to avoid damage to the sprinklers - before, during, and after installation. Sprinklers damaged by dropping, striking, wrench twist/slippage, or the like, must be replaced. Also, replace any sprinkler that has a cracked bulb or that has lost liquid from its bulb. (Ref. Installation Section).

The owner is responsible for the inspection, testing, and maintenance of their fire protection system and devices in compliance with this document, as well as with the applicable standards of the National Fire Protec-

tion Association (e.g., NFPA 25), in addition to the standards of any other authorities having jurisdiction. The installing contractor or sprinkler manufacturer should be contacted relative to any questions.

It is recommended that automatic sprinkler systems be inspected, tested, and maintained by a qualified Inspection Service in accordance with local requirements and/or national codes.

Limited Warranty

Products manufactured by Tyco Fire Products are warranted solely to the original Buyer for ten (10) years against defects in material and workmanship when paid for and properly installed and maintained under normal use and service. This warranty will expire ten (10) years from date of shipment by Tyco Fire Products. No warranty is given for products or components manufactured by companies not affiliated by ownership with Tyco Fire Products or for products and components which have been subject to misuse, improper installation, corrosion, or which have not been installed, maintained, modified or repaired in accordance with applicable Standards of the National Fire Protection Association, and/or the standards of any other Authorities Having Jurisdiction. Materials found by Tyco Fire Products to be defective shall be either repaired or replaced, at Tyco Fire Products' sole option. Tyco Fire Products neither assumes, nor authorizes any person to assume for it, any other obligation in connection with the sale of products or parts of products. Tyco Fire Products shall not be responsible for sprinkler system design errors or inaccurate or incomplete information supplied by Buyer or Buyer's representatives.

IN NO EVENT SHALL TYCO FIRE PRODUCTS BE LIABLE, IN CONTRACT, TORT, STRICT LIABILITY OR UNDER ANY OTHER LEGAL THEORY, FOR INCIDENTAL, INDIRECT, SPECIAL OR CONSEQUENTIAL DAMAGES, INCLUDING BUT NOT LIMITED TO LABOR CHARGES, REGARDLESS OF WHETHER TYCO FIRE PRODUCTS WAS INFORMED ABOUT THE POSSIBILITY OF SUCH DAMAGES, AND IN NO EVENT SHALL TYCO FIRE PRODUCTS' LIABILITY EXCEED AN AMOUNT EQUAL TO THE SALES PRICE.

THE FOREGOING WARRANTY IS MADE IN LIEU OF ANY AND ALL OTHER WARRANTIES EXPRESS OR IMPLIED, INCLUDING WARRANTIES OF MERCHANTABILITY AND FITNESS FOR A PARTICULAR PURPOSE.

Ordering Procedure

When placing an order, indicate the full product name. Please specify the Sprinkler Identification Number (SIN), quantity, and temperature rating. Refer to the Price List for complete listing of Part Numbers.

Contact your local distributor for availability.

Sprinkler Assemblies with NPT Thread Connections:

Specify: TY5153, 11.2 K-factor, Model LD Upright Large Drop Sprinkler, P/N (specify).

155°F/68°C	P/N 50-400-2-155
200°F/93°C	P/N 50-400-2-200
286°F/141°C	P/N 50-400-2-286

Sprinkler Wrench:

Specify: W-Type 3 Sprinkler Wrench, P/N 56-895-1-001.

